

Product Specification

Ord.-No.: **111 334**

Specification: Connecting clamp with spring, St/tZn
Ø 6-20 reinforcement / fl. 30 or Ø 10 mm

Performance: Connecting clamp with clamping bracket and compression spring according to DIN EN 62561-1 for the connection of flat or round conductors with the reinforcement in the concrete foundation.

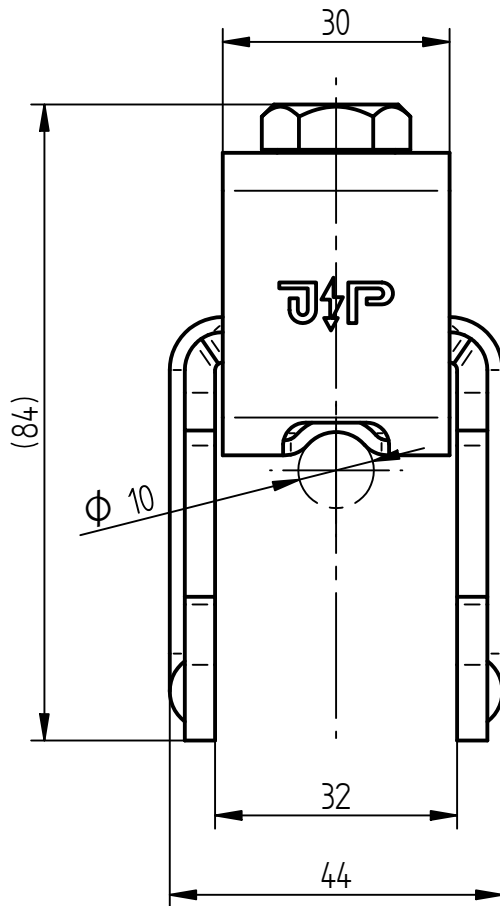

Compression spring holds up clamping bracket during assembly

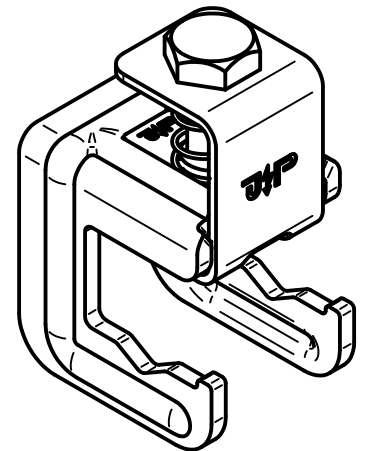
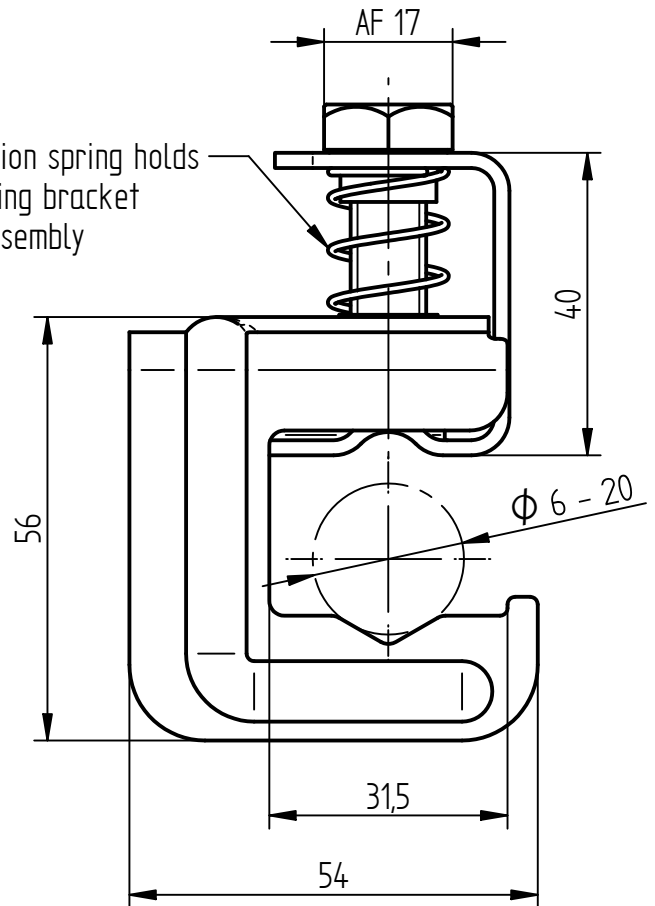

Material	St/tZn
Type of clamp	flat or round on reinforcement
Fit	fl. 30 mm or Ø 10 mm/Ø 6-20 mm
Alternative fit	flat on flat, fl. 30 mm/fl. 30 mm
Screw	Hexagon bolt M10, St/tZn
Weight	282 g
Standard reference	DIN EN 62561-1
Packing unit	25 units